

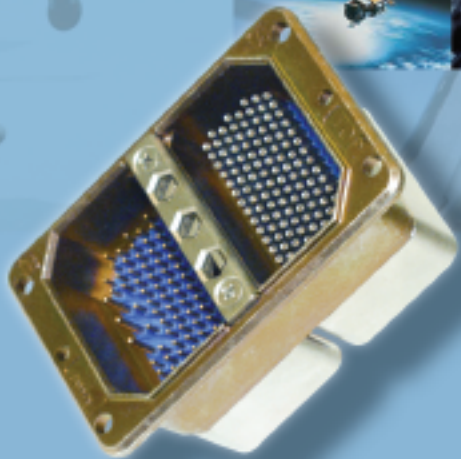

ITT

Electronic Components

Cannon Chip-on-Flex Filter Connectors

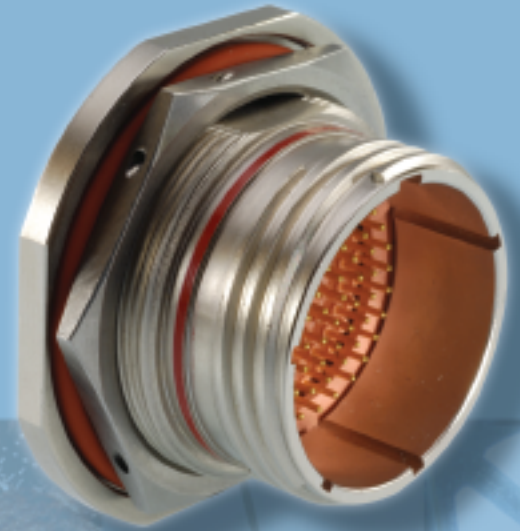

Engineered for life

Technology Update

With the increasing demand for lighter weight and more rugged filter connectors, ITT Electronic Components, has advanced the state of the art in filter technology with the new Cannon Chip-on-Flex (CoF) design.

Cannon's Chip-on-Flex filter connector technology provides a significant performance improvement in thermal shock and vibration to the ceramic planar array technology that is the current industry standard. The current planar array design utilizes a ceramic block capacitor with plated thru holes where feed thru contacts are inserted and soldered into place. Internal stresses associated with vibration, thermal expansion/contraction

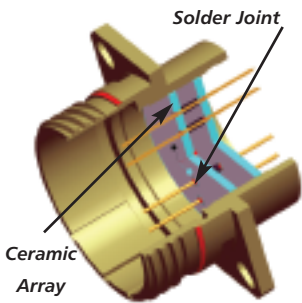

**MIL-DTL-38999 Type
Current Planar Array Design**

can build at the solder joints and cause the ceramic material to crack resulting in a filter failure. As a consequence, costly thermal shock screening and burn in procedures are often used for quality assurance.

In the new Cannon Chip-on-Flex design, the internal thermal shock stresses have been virtually eliminated. The fragile ceramic planar array capacitor block has been

replaced by a flex circuit where individual chip capacitors are surface mounted on a pad adjacent to the feed thru contact.

The result is a very robust filter connector with superior mechanical performance and improved reliability.

New Design/Development Flexibility and Reduced Leadtimes

Cannon's Chip-on-Flex filter design offers the system designer new and complete flexibility in defining or changing individual circuit requirements without the need to retool the ceramic planar array. The Chip-on-Flex design utilizes readily available flex circuits and devices leading to reduced design / development cycle time and overall production delivery.

1. Virtually no limitations on the variation in capacitance/feed-thru/ground/diode choices that is readily available to the customer. The exact same flex circuit is used. Cannon installs the appropriate device in each location as selected by the customer.
2. EMP protection can be simply added by substituting a Zener diode in place of a chip capacitor.

Rugged Design plus up to 15% Savings in Weight

Cannon's new Chip-on-Flex filter connector has the additional benefit of being the lightest weight design. The MIL-DTL-38999 Series III type CoF offers up to a 15% savings in weight over the ceramic planar array equivalent.

The new Chip-on-Flex connector will protect critical circuits from electrical interference providing a "stray signal barrier" upstream and away from electronic devices without affecting system function and performance.

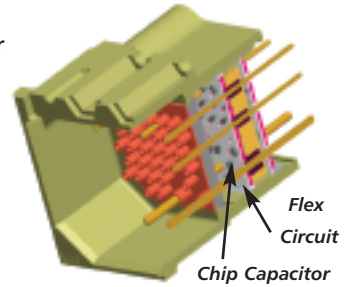

**ARINC 404 Type
New Chip-on-Flex Design**

The Chip-on-Flex filter connector provides all the same benefits of filter connector technologies.

1. Individual isolated pin filtering of high frequency noise, shunted to ground via the connector shell. The cut-in frequency of the filtering is selected by the user from the performance attenuation curves.
2. Built-in ground plane barrier in the connector insert. This eliminates EMI windows on the face of systems where connectors enter or exit boxes.
3. Filtering at the face of system boxes eliminating filtering on the PCB, freeing up board space, and maintaining EMI integrity of the system by not allowing unwanted signals to enter the box.

Applications

The CoF filter connectors are ideal for high reliability military, aerospace and industrial applications:

- Integrated Avionics Systems
- Communication and Navigation
- Displays and Instrumentation
- Data Processing Equipment
- Electronic Warfare Systems
- Radar and Sensors
- Weapons Controls and Targeting Systems
- Electronic Counter Measures
- Satellites and Space Systems



Well Mount Receptacle



CFKJA0

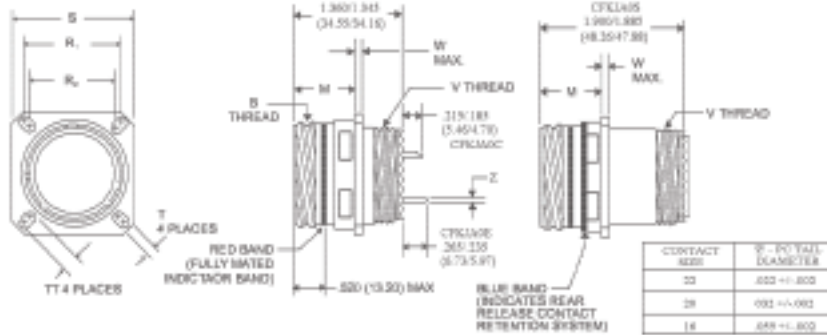

CONTACT SIZE	W - PCTAIL DIAMETER
22	.021 ±.002
26	.032 ±.002
16	.049 ±.002

Shell Size	MS Shell size Code	B Thread Class 2A (Plated)	M ±.000 (.000) -.005 (-.130)	R ₁	R ₂	S ±.012 (.300)	T ±.004 (.100) -.002 (-.050)	TT ±.004 (.100) -.002 (-.050)	Metric V Thread (Plated)	W Max.
9	A	.850-0.1P-0.3L-TS	.820 (20.60)	.718 (18.36)	.586 (15.09)	.830 (23.00)	-.126 (3.25)	.218 (5.49)	M12X1-8gB 100R	.040 (2.50)
15	B	.750-0.1P-0.3L-TS	.820 (20.60)	.812 (20.62)	.719 (18.29)	1.031 (26.19)	-.126 (3.25)	.194 (4.93)	M18X1-8gB 100R	.040 (2.50)
13	C	.870-0.1P-0.3L-TS	.820 (20.60)	.808 (20.61)	.812 (20.62)	1.126 (28.64)	-.126 (3.25)	.194 (4.93)	M18X1-8gB 100R	.040 (2.50)
15	D	1.000-0.1P-0.3L-TS	.820 (20.60)	.868 (24.61)	.866 (22.01)	1.219 (30.96)	-.126 (3.25)	.173 (4.39)	M22X1-8gB 100R	.040 (2.50)
17	E	1.167-0.1P-0.3L-TS	.820 (20.60)	1.082 (28.87)	.869 (22.01)	1.372 (33.32)	-.126 (3.25)	.194 (4.93)	M26X1-8gB 100R	.040 (2.50)
19	F	1.250-0.1P-0.3L-TS	.820 (20.60)	1.158 (29.36)	1.082 (28.97)	1.430 (36.50)	-.126 (3.25)	.194 (4.93)	M26X1-8gB 100R	.040 (2.50)
21	G	1.375-0.1P-0.3L-TS	.790 (20.07)	1.258 (31.75)	1.199 (29.36)	1.562 (39.67)	-.126 (3.25)	.194 (4.93)	M30X1-8gB 100R	.126 (3.20)
23	H	1.500-0.1P-0.3L-TS	.790 (20.07)	1.375 (34.82)	1.293 (32.75)	1.880 (42.68)	-.154 (3.91)	.242 (6.15)	M36X1-8gB 100R	.126 (3.20)
25	J	1.625-0.1P-0.3L-TS	.790 (20.07)	1.500 (38.10)	1.375 (34.92)	1.812 (46.02)	-.154 (3.91)	.242 (6.15)	M36X1-8gB 100R	.126 (3.20)

Jam Nut Receptacle



CFKJA7

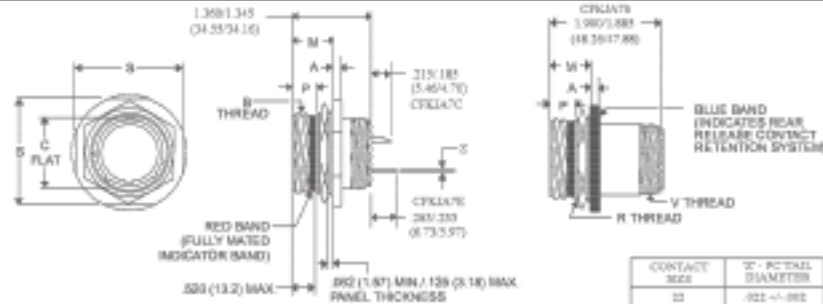

CONTACT SIZE	W - PCTAIL DIAMETER
22	.021 ±.002
26	.032 ±.002
16	.049 ±.002

Shell Size	MS Shell size Code	A ±.018 (.250) -.005 (-.130)	B Thread Class 2A (Plated)	C ±.004 (.100) -.018 (-.300)	M ±.005 (.130) -.004 (-.100)	P ±.016 (.410) -.004 (-.100)	S ±.016 (.410)	Metric R Thread (Plated)	Metric V Thread (Plated)
9	A	.504 (2.64)	.820-0.1P-0.3L-TS	.891 (18.80)	.871 (22.12)	.989 (14.10)	1.082 (28.87)	M17X1-8gB 100R	M12X1-8gB 100R
11	B	.504 (2.64)	.750-0.1P-0.3L-TS	.751 (19.07)	.871 (22.12)	.989 (14.10)	1.280 (31.76)	M20X1-8gB 100R	M15X1-8gB 100R
13	C	.504 (2.64)	.870-0.1P-0.3L-TS	.838 (23.62)	.878 (22.30)	.983 (14.30)	1.375 (34.92)	M26X1-8gB 100R	M18X1-8gB 100R
15	D	.504 (2.64)	1.000-0.1P-0.3L-TS	1.062 (26.97)	.878 (22.30)	.983 (14.30)	1.500 (38.10)	M26X1-8gB 100R	M22X1-8gB 100R
17	E	.504 (2.64)	1.167-0.1P-0.3L-TS	1.167 (30.15)	.878 (22.30)	.983 (14.30)	1.625 (41.26)	M32X1-8gB 100R	M26X1-8gB 100R
19	F	.536 (3.43)	1.250-0.1P-0.3L-TS	1.312 (33.32)	.878 (22.30)	.983 (14.30)	1.812 (46.02)	M36X1-8gB 100R	M26X1-8gB 100R
21	G	.536 (3.43)	1.375-0.1P-0.3L-TS	1.437 (36.80)	.878 (22.30)	.983 (14.30)	1.938 (49.22)	M40X1-8gB 100R	M30X1-8gB 100R
23	H	.536 (3.43)	1.500-0.1P-0.3L-TS	1.562 (39.87)	.878 (22.30)	.983 (14.30)	2.062 (52.37)	M46X1-8gB 100R	M36X1-8gB 100R
25	J	.536 (3.43)	1.625-0.1P-0.3L-TS	1.687 (42.85)	.878 (22.30)	.983 (14.30)	2.188 (55.38)	M46X1-8gB 100R	M36X1-8gB 100R

Ordering Information

CFKJA0E*NLPP

Product Prefix (MIL-DTL-38999)

MIL-DTL-38999 Series

- I - L
- II - blank
- III - A
- IV - B (receptacles only)

Shell Style

- 0 - Front Wall Mount Receptacle
- 2 - Front Box Mount Receptacle
- 3 - Rear Wall Mount Receptacle
- 5 - Rear Box Mount Receptacle
- 7 - Jam Nut Mount Receptacle
- 6 - Plug - EMI Grounded
- 8 - In-line Adapter

Termination

- E - pc tail, .250 extension, .250 size 22, .0350 size 20, .0600 size 16
- C - solder pot, .250 extension
- S - crimp piggy-back
- W - wire wrap, .400 extension, .025 square size 22

Shell Size

Insert Arrangement

Filter Type

- C - C filter
- P - Pi filter
- F - L filter

Polarization

- N, A, B, C, D, E per MIL-DTL-38999

Contact Type

- P - pin
- S - socket
- PS - adapter pin side @ receptacle end
- SP - adapter socket side @ receptacle end

Standard Capacitance Range

- H - 1100pF ±20%
- T - 4200pF ±20%
- M - 10,100pF ±20%
- L - 38,000pF ±20%

Finish

- N - Electroless Nickel (preferred)
- B - Olive Drab Chromate over Cadmium over Nickel
- R - Zinc alloy over Ni (RoHS compliant)

(Note - styles 2, 3 and 5 for Series I & II only)

* Shell size and Insert Arrangements per MIL-DTL-38999.

Also available in accordance with applicable portions of MIL-DTL-24308, MIL-C-26482, MIL-C-81659 & ARINC 600

Contact Arrangements

Engaging view, pin insert

Series I, III & IV	9-35	11-5	11-98	11-35	13-8	13-98	13-35
Series II	8-35	10-5	10-98	10-35	12-8	12-98	12-35
No. of Contacts	6 #22D	5 #20	6 #20	13 #22D	8 #20	10 #20	22 #22D
Service Ratings	M	I	I	M	I	I	M
Series I, III & IV	15-5	15-18	15-19	15-35	-	17-8	17-35
Series II	14-5	14-18	14-19	14-35	16-99	16-8	16-35
No. of Contacts	5 #16	18 #20	19 #20	37 #22D	21 #20, 2 #16	8 #16	55 #22D
Service Ratings	II	I	I	M	I	II	M
Series I, III & IV	19-32	19-35	21-16	21-35	21-41	19-32	19-35
Series II	18-32	18-35	20-16	20-35	20-41	18-32	18-35
No. of Contacts	32 #20	66 #22D	16 #16	79 #22D	41-#20	32 #20	66 #22D
Service Ratings	I	M	II	M	I	I	M
Series I, III & IV	23-21	23-35	23-53	23-55	23-21	23-35	23-53
Series II	22-21	22-35	22-53	22-55	22-21	22-35	22-53
No. of Contacts	21 #16	100 #22D	53 #20	55 #20	21 #16	100 #22D	53 #20
Service Ratings	II	M	I	I	II	M	I
Series I, III & IV	25-29	25-35	25-61	25-29	25-35	25-61	25-29
Series II	24-29	24-35	24-61	24-29	24-35	24-61	24-29
No. of Contacts	29 #16	128 #22D	61 #20	29 #16	128 #22D	61 #20	29 #16
Service Ratings	I	M	I	I	M	I	I

Please consult factory for availability of layouts not shown

Attenuation Curves

Cannon's Chip-on-Flex filter connectors has passed MIL-DTL-38999 Series III testing for thermal shock, random vibration, humidity and high altitude DMV. These connectors are ideal for high reliability military aerospace and industrial applications.

This new filter technology is available in almost all series of Cannon standard connectors:

MIL SPEC

MIL-DTL-38999, Series I
 MIL-DTL-38999, Series II
 MIL-DTL-38999, Series III
 MIL-DTL-38999, Series IV
 MIL-C-26482, Series II
 MIL-DTL-24308
 MIL-C-81659 (ARINC 404)
 ARINC 600

P/N LEAD-OFF

CFKJL
 CFKJ
 CFKJA
 CFKJB
 CFPV
 CFD
 CFDPX
 CFBKA

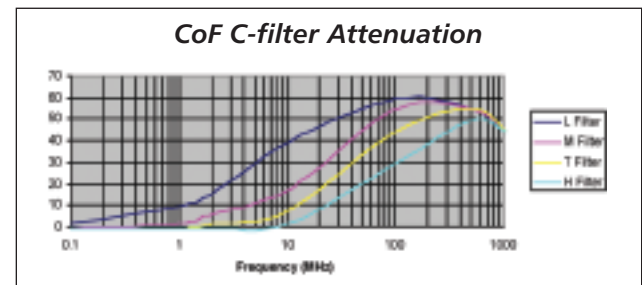
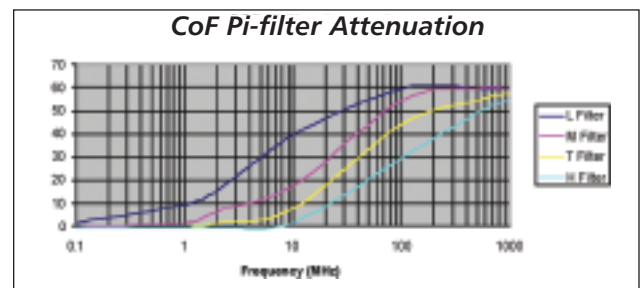

MIL-DTL-38999 Filter Performance

Based on Design Verification Testing, Chip-on-Flex Filter Connectors meet or exceed the following applicable performance requirements from MIL-DTL-38999.

Test Description	Paragraph	Requirements																
Insulation Resistance	4.5.9	Insulation resistance test is performed on unmated connectors per MIL-STD-1344, method 3003. The test voltage is 100 Vdc minimum. Standard quality conformance testing is done, where all contacts are measured to all other contacts and the shell at room temperature. The minimum requirement is 5,000 Megohms at room temperature and 1,000 Megohms at 125°C.																
Dielectric Withstanding Voltage (DWV)	4.5.10	Dielectric Withstanding Voltage (DWV) is performed on unmated connectors per MIL-STD-1344, method 3001. Standard quality conformance testing is done, where all contacts are measured to all other contacts and the shell at room temperature. Leakage current shall not exceed 100 microamps at the shown minimum test voltages.																
		<table border="0"> <tr> <td>Contact Size</td> <td>22 with 'M', 'T' & 'H' range filters</td> <td>22 with 'L' range filters</td> <td>20, 16 & 12</td> </tr> <tr> <td>Test Voltage</td> <td>500 Vdc</td> <td>300 Vdc</td> <td>500 Vdc</td> </tr> </table>	Contact Size	22 with 'M', 'T' & 'H' range filters	22 with 'L' range filters	20, 16 & 12	Test Voltage	500 Vdc	300 Vdc	500 Vdc								
		Contact Size	22 with 'M', 'T' & 'H' range filters	22 with 'L' range filters	20, 16 & 12													
Test Voltage	500 Vdc	300 Vdc	500 Vdc															
Contact Retention	4.5.19	After preloading to 3 pounds maximum, the force is applied at approximately 1 pound per second and maintained at full load for 5-10 seconds. There is no damage to contacts or inserts and filter attenuation minimum values are met after testing. Filter contacts are non-removable.																
		<table border="0"> <tr> <td>Contact Size</td> <td>22</td> <td>20</td> <td>16</td> <td>12</td> </tr> <tr> <td>Load in Pounds + / - 10%</td> <td>10</td> <td>15</td> <td>25</td> <td>25</td> </tr> </table>	Contact Size	22	20	16	12	Load in Pounds + / - 10%	10	15	25	25						
		Contact Size	22	20	16	12												
Load in Pounds + / - 10%	10	15	25	25														
Vibration	4.5.22	Wired, mated connectors are vibrated by mounting filter receptacles on the vibration fixture by normal means. There are no pin-socket electrical discontinuities exceeding 1 microsecond with 100/500 milliamps of current flowing during vibration testing. There is no disengagement of mated connectors, evidence of cracking, breaking or loosening of parts. Filter attenuation minimum values are met after testing.																
		Series I and IV	a) MIL-STD-202, Method 204, Condition G (30g sine, 4 hrs in 3 axis) b) MIL-STD-1344, Method 2005, Condition VI, Letter J (Random, 8 hrs in 2 axis) c) MIL-STD-1344, Method 2005, MIL-DTL-38999 Figure 25 (Random, 8 hrs in 2 axis, no weights)															
		Series II	MIL-STD-1344, M2005, Cond. VI, Ltr J (Random, 8 hrs in 2 axis)															
		Series III	a) MIL-STD-1344, Method 2005, Condition VI, Letter J (Random, 8 hrs in 2 axis at high temp) b) MIL-STD-1344, Method 2005, MIL-DTL-38999 Figure 25 (Random, 8 hrs in 2 axis, no weights)															
Mechanical Shock	4.5.23.1	Wired, mated connectors are subjected to 300g half sinusoidal shocks per MIL-STD-1344, method 2004, condition D. Filter receptacles are mounted on the shock fixture by normal means. There are no pin-socket electrical discontinuities exceeding 1 microsecond with 100/500 milliamps of current flowing during shock testing. There is no disengagement of mated connectors, evidence of cracking, breaking or loosening of parts. Filter attenuation minimum values are met after testing.																
Thermal Shock	4.5.4	Unmated connectors are subjected to 25 cycles of temperature cycling per MIL-STD-1344, method 1003, condition A except temperature extremes are -65/-68°C and +122/125°C. There is no damage detrimental to the operation of the connectors. Filter attenuation minimum values are met after testing.																
High Altitude DWV	4.5.10.2	Unmated connectors are tested per MIL-STD-1344, method 3001 at the test voltages below. Only the engaging face of receptacles are subjected to the high altitude (rear face is suitably protected). Leakage current shall not exceed 100 microamps at the shown minimum test voltages.																
		<table border="0"> <tr> <td>Contact Size</td> <td>22 with 'M', 'T' & 'H' range filters</td> <td>22 with 'L' range filter</td> <td>20, 16 & 12</td> </tr> <tr> <td>50,000 feet</td> <td>400</td> <td>240</td> <td>400</td> </tr> <tr> <td>70,000 feet</td> <td>260</td> <td>150</td> <td>260</td> </tr> <tr> <td>100,000 feet</td> <td>200</td> <td>125</td> <td>200</td> </tr> </table>	Contact Size	22 with 'M', 'T' & 'H' range filters	22 with 'L' range filter	20, 16 & 12	50,000 feet	400	240	400	70,000 feet	260	150	260	100,000 feet	200	125	200
		Contact Size	22 with 'M', 'T' & 'H' range filters	22 with 'L' range filter	20, 16 & 12													
		50,000 feet	400	240	400													
		70,000 feet	260	150	260													
100,000 feet	200	125	200															

Filter connector characteristics under Coupling Torque, Durability, Corrosion, Shell-to-shell Conductivity, Contact Resistance, Insert Retention, Temperature Exposure and Humidity testing are identical to those of non-filtered MIL specification versions. Standard Operating Parameters:

Maximum Operating Voltage – 200 Vdc or 120 Vac rms at 400 Hz	Contact current rating (dc)	15 amps size 16 7.5 amps size 20 5 amps size 22
Contact RF current rating – 11 milliamps rms		



ITT

Connector Product Locations

With manufacturing facilities, sales representatives and distributors located worldwide, please visit our website at www.ittcannon.com for a complete listing and to find the office nearest you.

GERMANY

Cannonstrasse 1
Weinstadt, 71384
phone: 49.7151.699.0
fax: 49.7151.699.217

HONG KONG

Unit 901 & 912, West Tower
Shun Tak Center
168-200 Connaught Road
Central
phone: 852.2732.2720
fax: 852.2732.2919

ITALY

Via Pietro Panzeri 10
Milano, 20123
phone: 39.2.58180.1
fax: 39.2.8372036

UK

Jays Close, Viabes Estate
Basingstoke, RG22 4BA
phone: 44.1256.311200
fax: 44.1256.323356

USA

666 East Dyer Road
Santa Ana, CA 92705
toll free: 1.800.854.3028
phone: 1.714.557.4700
fax: 1.714.628.2142

"Engineered for life" is a registered trademark of ITT Industries. ©2005. All other trademarks or registered trademarks are property of their respective owners. All data subject to change without notice.

www.ittcannon.com

CoF 05-Sept